



LOC

Cooling system – optimized for industrial use



The Olaer Group is a global player specialising in innovative, efficient system solutions for temperature optimisation and energy storage. All over the world, our products are working in the most diverse environments and applications, e.g. the aircraft, engineering, steel and mining industries, as well as in sectors such as oil and gas, contracting and transport, farming and forestry, renewable energy, etc.

LOC Cooling System

For industrial use - maximum cooling capacity 45 kW

The LOC cooling system with three-phase AC motor is optimized for use in the industrial sector. The system is supplied ready for installation. An integrated circulation pump makes it possible to cool and treat the oil in a separate circuit – offline cooling. The cooling system is also available with the FX3 filter unit.

Together with a wide range of accessories, the LOC cooling system is suitable for installation in most applications and environments. The maximum cooling capacity is 45 kW at ETD 40 °C.

Choosing the right cooling system requires precise sizing. The most reliable way to size is with the aid of Oiltech's calculation program. This program, together with precise evaluations from our experienced, skilled engineers, gives you the opportunity for more cooling per € invested.



Overheating - an expensive problem

An under-sized cooling capacity produces a temperature balance that is too high. The consequences are poor lubricating properties, internal leakage, a higher risk of cavitation, damaged components, etc. Overheating leads to a significant drop in cost-efficiency and environmental consideration.

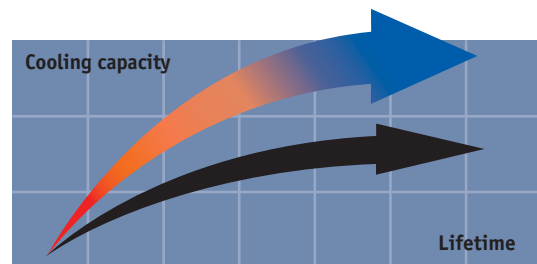

Temperature optimisation – a basic prerequisite for cost-efficient operation

Temperature balance in a hydraulic system occurs when the cooler can cool down the energy input that the system does not consume - the system's lost energy ($P_{loss} = P_{cool} = P_{in} - P_{used}$).

Temperature optimisation means that temperature balance occurs at the system's ideal working temperature – the temperature at which the oil's viscosity and the air content comply with recommended values. The correct working temperature produces a number of economic and environmental benefits:

- The hydraulic system's useful life is extended.
- The oil's useful life is extended.
- The hydraulic system's availability increases - more operating time and fewer shutdowns.
- Service and repair costs are reduced.
- High efficiency level maintained in continuous operation – the system's efficiency falls if the temperature exceeds the ideal working temperature.

Clever design

and the right choice of materials and components produce a long useful life, high availability and low service and maintenance costs.

Integrated circulation pump

produces an even flow with low pressure pulsations.

Easy to maintain

and easy to retrofit in many applications.



Cooler matrix with low pressure drop

and high cooling capacity.

Quiet

fan and fan motor.

Compact design

and low weight.

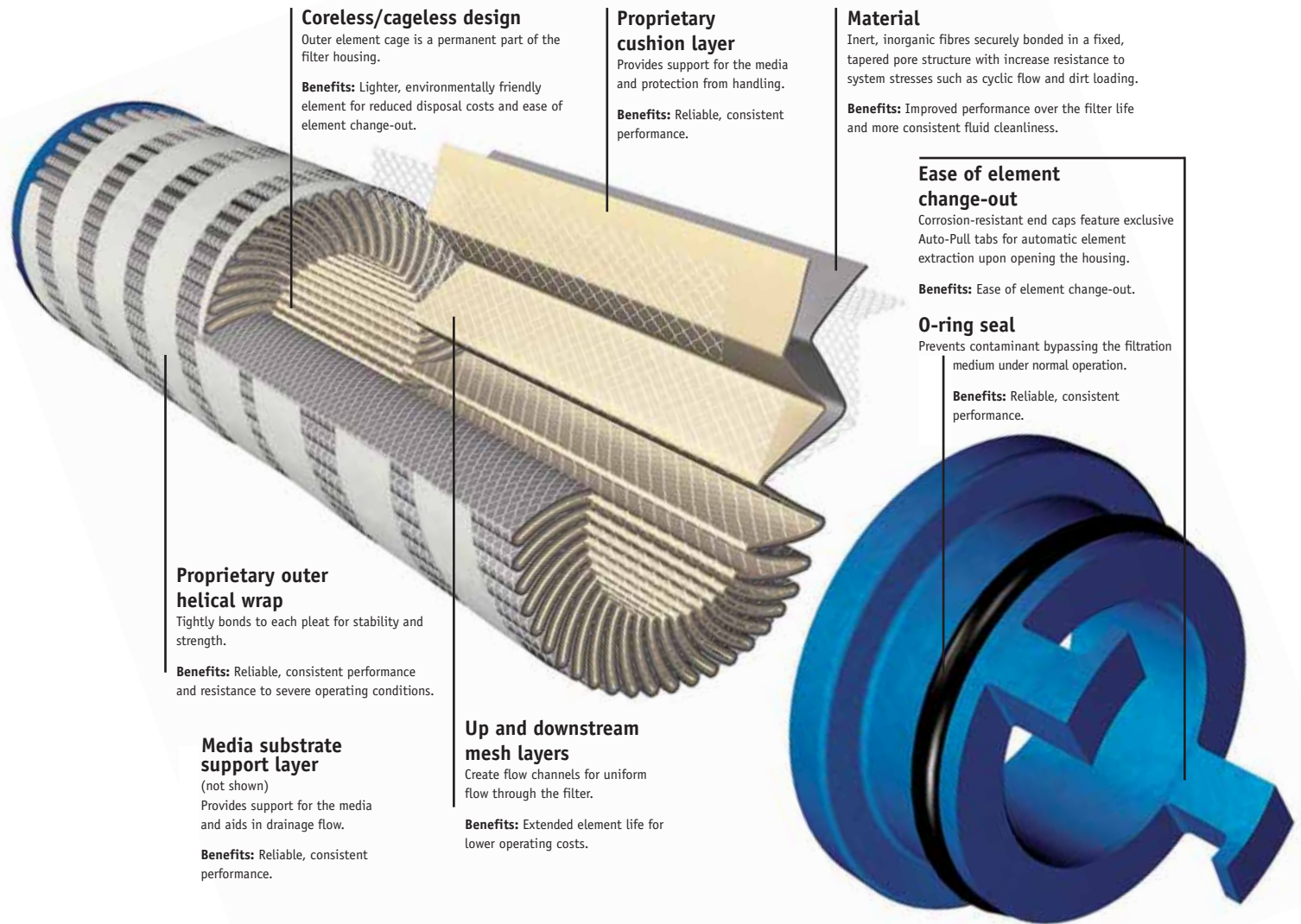

Coreless/cageless design

Outer element cage is a permanent part of the filter housing.

Benefits: Lighter, environmentally friendly element for reduced disposal costs and ease of element change-out.

Proprietary cushion layer

Provides support for the media and protection from handling.

Benefits: Reliable, consistent performance.

Material

Inert, inorganic fibres securely bonded in a fixed, tapered pore structure with increase resistance to system stresses such as cyclic flow and dirt loading.

Benefits: Improved performance over the filter life and more consistent fluid cleanliness.

Ease of element change-out

Corrosion-resistant end caps feature exclusive Auto-Pull tabs for automatic element extraction upon opening the housing.

Benefits: Ease of element change-out.

O-ring seal

Prevents contaminant bypassing the filtration medium under normal operation.

Benefits: Reliable, consistent performance.

Proprietary outer helical wrap

Tightly bonds to each pleat for stability and strength.

Benefits: Reliable, consistent performance and resistance to severe operating conditions.

Media substrate support layer

(not shown)
Provides support for the media and aids in drainage flow.

Benefits: Reliable, consistent performance.

Up and downstream mesh layers

Create flow channels for uniform flow through the filter.

Benefits: Extended element life for lower operating costs.

Good things come in small packages...

Characteristics

- Stress-resistant design
- Uniform pore size control layer
- Tapered pore structure
- Epoxy resin bonded fibre matrix with small fibre size
- Anti-static design

Benefits

- Enhanced performance under cyclic flow and pressure conditions
- Maintained efficiency during the entire life
- Dirt captured throughout the media depth
- High particles removal efficiency
- Minimized static charge generation and electrostatic discharge

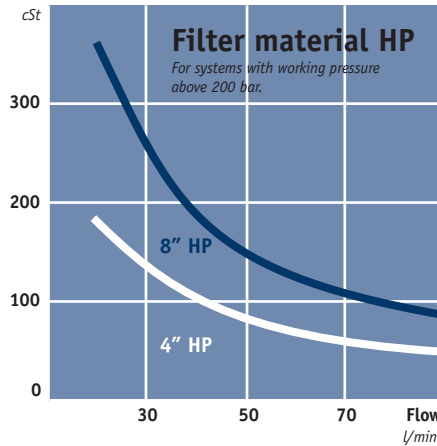
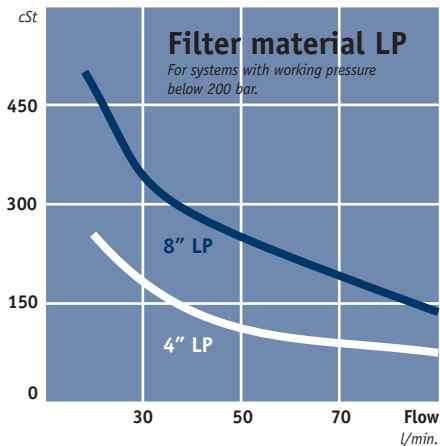

Choose the right filter element:

- 1) **Filter material HP or LP** – depends on pressure level, i.e. the system's average pressure.
- 2) **The filter's flow capacity** – the oil flow is determined by the LOC cooler model, i.e. current cooling requirement.
- 3) **The length of the filter element** – depends on the operating viscosity. The pressure drop over the filter element is proportional to the viscosity, e.g. oil that is three times as thick produces a pressure drop that is three times as high.



The FX3 original filter gives you constantly cleaner oil, more lasting system protection and greater stability during operation at varying flow and pressure.

The FX3 captures dirt along the whole length of the filter material and retains efficiency throughout its useful life.

The element is easy to replace, it comes out when you unscrew the cover - it couldn't be simpler.

FX3 Original Filter

element makes difference

Why not clean the oil while cooling it? Equipped with our filter unit FX3 the oil will be cleaned in a separate circuit, an ideal complement to the system filter. Our filter unit FX3 is available as option.

Filter technique

Designing filter media has traditionally been a question of balance. By making the medium finer, more efficient and cleaner, a pressure drop occurs and/or the serviceable life is sacrificed. To get a lower cleaner

pressure drop the removal efficiency is sacrificed.

With FX3 filter media has improved the filter's ability to maintain fluid cleanliness, while at the same time increasing flow capacity (reducing pressure drop).

The result is a better and more consistent system protection, i.e. high flow capacity in a small envelope size, optimum performance at stages of filter life, i.e. optimum performance under cyclic flow and pressure conditions for consistently cleaner fluid.



FX3 FILTER UNIT

- Compact
- Environmentfriendly
- Highly efficient

Calculate the cooling capacity requirement

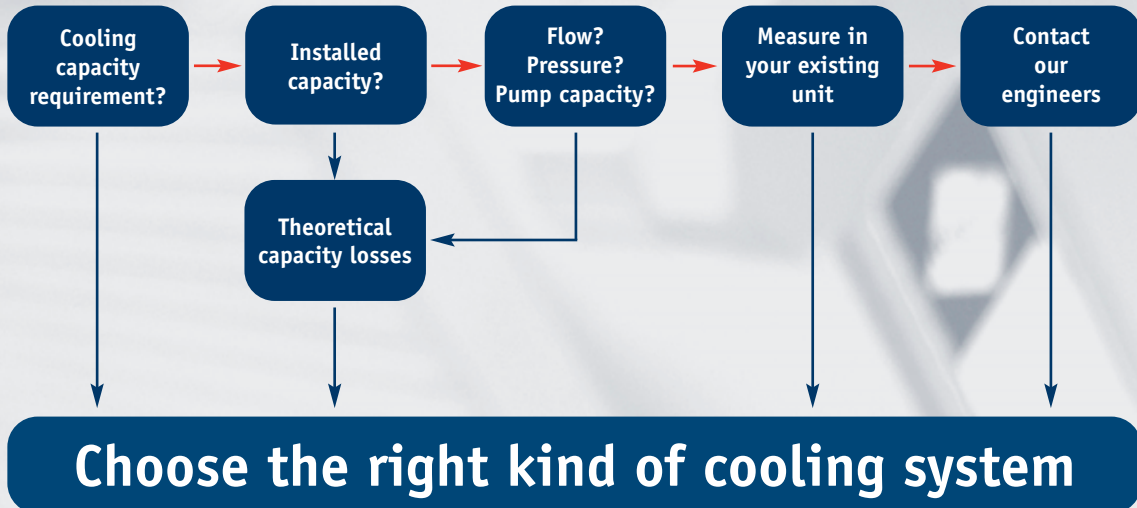

Enter your values...



...suggested solution



Better energy consumption means not only less environmental impact, but also reduces operating costs, i.e. more cooling per € invested.

More cooling per €

with precise calculations and our engineers' support

Optimal sizing produces efficient cooling. Correct sizing requires knowledge and experience. Oiltech's calculation program, combined with our engineers' support, gives you access to this very knowledge and experience. The result is more cooling per € invested.

The user-friendly calculation program can be downloaded from Oiltech's website – www.oiltech.se.

Valuable system review into the bargain

A more wide-ranging review of the hydraulic system is often a natural element of cooling calculations. Other potential system improvements can then be discussed – e.g. filtering, offline or online cooling, etc. Contact us for further guidance and information.

Oiltech's quality and performance guarantee insurance for your operations and systems

A constant striving towards more cost-efficient and environmentally-friendly hydraulic systems requires continuous development. Areas where we are continuously seeking to improve performance include cooling capacity, noise level, pressure drop and fatigue.

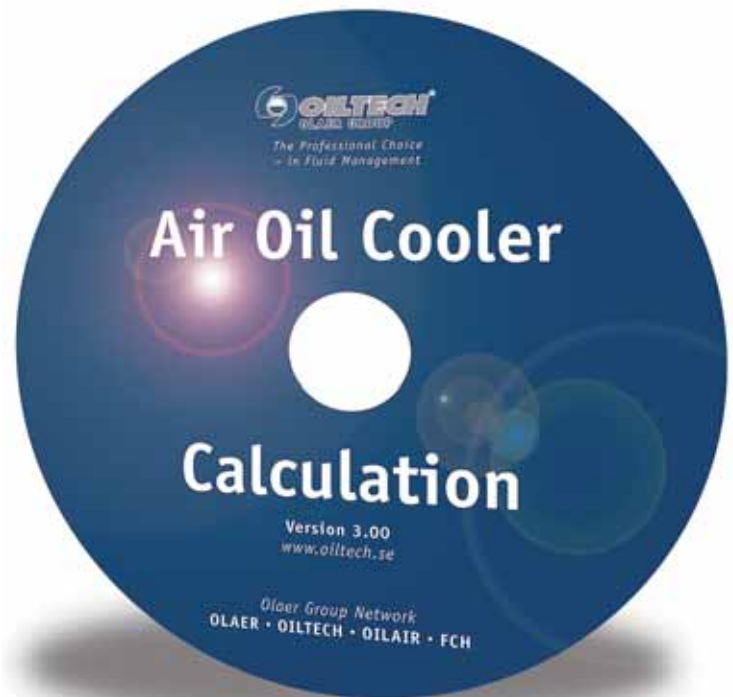

Meticulous quality and performance tests are conducted in Oiltech's laboratory. All tests and measurements take place in accordance with standardised methods - cooling capacity in accordance with EN1048, noise level ISO 3743, pressure drop EN 1048 and fatigue ISO 10771-1.

For more information about our standardised tests, ask for "Oiltech's blue book – a manual for more reliable cooler purchasing".

Technical specification

- LOC is designed primarily for synthetic oils, vegetable oils and mineral oil type HL/HLP in accordance with DIN 51524. Maximum oil temperature 100 °C.
- Maximum negative pressure in the inlet line is 0.4 bar with an oil-filled pump. Maximum pressure on the pump's suction side is 0.5 bar.
- Maximum working pressure for the pump is 10 bar. For information about suction height, pressure, etc. see the QPM3 pump manual.

Heat transfer tolerance $\pm 6\%$

3-PHASE MOTOR

3-phase asynchronous motor in accordance with IEC 60034-1.

Nominal voltage	*
Insulation class	F
Rise of temperature	B
Protection class	IP 55
Recommended ambient temperature	-20 °C – +40 °C

* = See separate instructions for electric motor.

All data is valid at 50 Hz.

MATERIAL

Pump housing/Cooler matrix	Aluminum
Fan blades/Hub:	Glass fibre reinforced polypropylene/aluminium
Fan housing	Steel
Fan guard	Steel
Other parts	Steel
Surface treatment	Electrostatically powder-coated

Other versions of the cooling system may have other materials and surface treatments.

FX3 FILTER UNIT (option) Aluminum

The filter housing has a built-in bypass valve, pre-set pressure 3.4 ± 0.3 bar.

CONTACT US FOR ADVICE ON

- oil temperatures > 100°C
- oil viscosity > 100 cSt
- other fluids
- aggressive environment
- ambient air rich in particles
- high-altitude locations

TYPE	Nom. oil flow l/min	Cooling capacity in kW at EDT 40°C	Cooling capacity kW/°C	Acoustic pressure level LpA dB(A) 1m**	No. of poles/ Capacity kW*	Weight kg (approx)
LOC 004-4-D-A	20	2.7	0.07	57	4-0.75	23
LOC2 007-4-D-A	20	5.6	0.14	64	4-0.75	30
LOC2 007-4-D-B	40	7.2	0.18	64	4-0.75	30
LOC2 007-4-D-C	60	8.0	0.20	65	4-1.50	36
LOC2 007-4-D-D	80	8.4	0.21	65	4-1.50	36
LOC2 011-4-D-A	20	9.2	0.23	70	4-0.75	34
LOC2 011-4-D-B	40	10.4	0.26	70	4-0.75	34
LOC2 011-6-D-C	40	7.6	0.19	61	6-1.10	40
LOC2 011-6-D-D	55	8.8	0.22	61	6-1.10	40
LOC2 011-4-D-C	60	12.0	0.30	70	4-1.50	40
LOC2 011-4-D-D	80	13.2	0.33	70	4-1.50	40
LOC2 016-4-D-A	20	11.2	0.28	74	4-1.50	45
LOC2 016-4-D-B	40	15.6	0.39	74	4-1.50	45
LOC2 016-6-D-C	40	12.4	0.31	64	6-1.10	45
LOC2 016-6-D-D	55	14.0	0.35	64	6-1.10	45
LOC2 016-4-D-C	60	18.0	0.45	74	4-1.50	45
LOC2 016-4-D-D	80	19.6	0.49	74	4-1.50	45
LOC2 023-4-D-B	40	21.2	0.53	77	4-1.50	53
LOC2 023-6-D-C	40	16.8	0.42	67	6-1.10	53
LOC2 023-6-D-D	55	18.4	0.46	67	6-1.50	53
LOC2 023-4-D-C	60	24.4	0.61	77	4-2.20	62
LOC2 023-4-D-D	80	26.8	0.67	77	4-2.20	62
LOC 033-6-A-D	55	26.0	0.65	74	6-2.20	92
LOC 033-4-A-C	60	32.0	0.80	85	4-3.00	76
LOC 033-4-A-D	80	34.8	0.87	85	4-3.00	76
LOC 044-6-A-D	55	34.0	0.85	77	6-2.20	98
LOC 044-4-A-C	60	40.0	1.00	86	4-3.00	85
LOC 044-4-A-D	80	44.8	1.12	86	4-3.00	85

* = Electric motors specified are calculated for max. working pressure 6 bar at 125 cSt and 50 Hz, 4 bar at 125 cSt and 60 Hz.

If you require higher pressure, please contact us for a choice of motors with a higher output.

** = Noise level tolerance ± 3 dB(A).

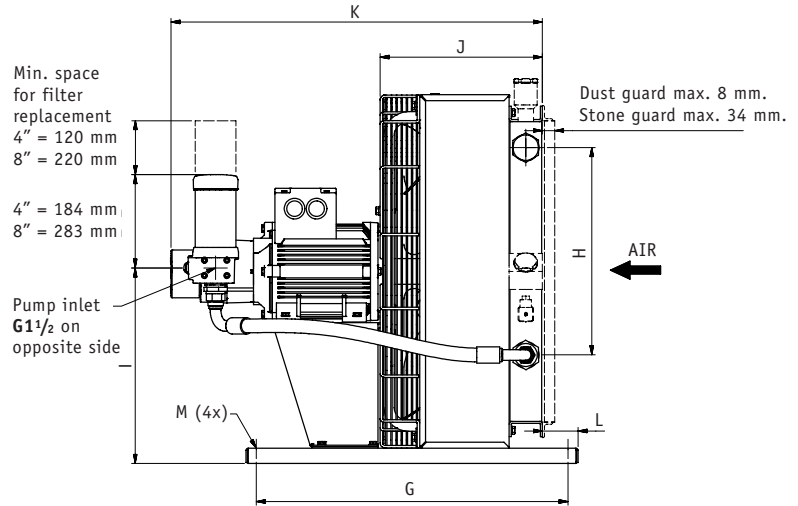
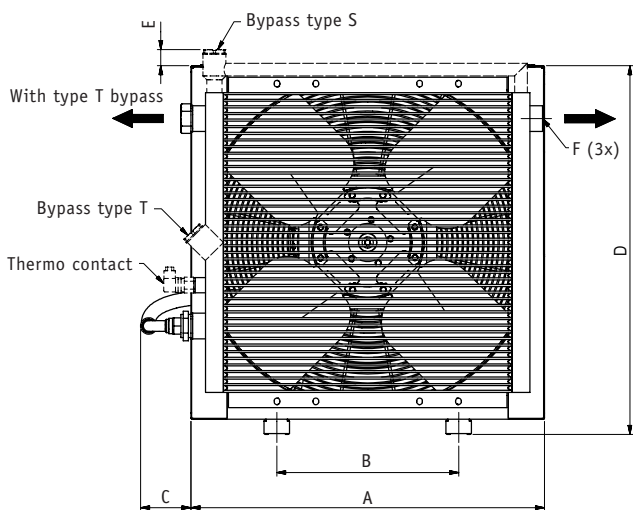

TYPE	A	B	C	D	E	F	G	H	I	J	K	L	M \varnothing
LOC 004-4-D-A	267	134	135	284	73	G1	420	90	164	163	488	58	9
LOC2 007-4-D-A	365	203	105	395	42	G1	510	160	215	225	558	50	9
LOC2 007-4-D-B	365	203	105	395	42	G1	510	160	215	225	571	50	9
LOC2 007-4-D-C	365	203	105	395	42	G1	510	160	215	225	620	50	9
LOC2 007-4-D-D	365	203	105	395	42	G1	510	160	215	225	633	50	9
LOC2 011-4-D-A	440	203	103	470	41	G1	510	230	252	249	582	50	9
LOC2 011-4-D-B	440	203	103	470	41	G1	510	230	252	249	595	50	9
LOC2 011-6-D-C	440	203	103	470	41	G1	510	230	252	249	643	50	9
LOC2 011-6-D-D	440	203	103	470	41	G1	510	230	252	249	657	50	9
LOC2 011-4-D-C	440	203	103	470	41	G1	510	230	252	249	644	50	9
LOC2 011-4-D-D	440	203	103	470	41	G1	510	230	252	249	657	50	9
LOC2 016-4-D-A	496	203	107	526	46	G1	510	230	285	272	640	50	9
LOC2 016-4-D-B	496	203	107	526	46	G1	510	230	285	272	653	50	9
LOC2 016-6-D-C	496	203	107	526	46	G1	510	230	285	272	665	50	9
LOC2 016-6-D-D	496	203	107	526	46	G1	510	230	285	272	678	50	9
LOC2 016-4-D-C	496	203	107	526	46	G1	510	230	285	272	665	50	9
LOC2 016-4-D-D	496	203	107	526	46	G1	510	230	285	272	678	50	9
LOC2 023-4-D-B	580	356	104	610	40	G1	610	305	322	287	668	50	14
LOC2 023-6-D-C	580	356	104	610	40	G1	610	305	322	287	722	50	14
LOC2 023-6-D-D	580	356	104	610	40	G1	610	305	322	287	722	50	14
LOC2 023-4-D-C	580	356	104	610	40	G1	610	305	322	287	709	50	14
LOC2 023-4-D-D	580	356	104	610	40	G1	610	305	322	287	722	50	14
LOC 033-6-A-D	692	356	99	722	32	G1 1/4	610	406	378	318	754	70	14
LOC 033-4-A-C	692	356	99	722	32	G1 1/4	610	406	378	318	727	70	14
LOC 033-4-A-D	692	356	99	722	32	G1 1/4	610	406	378	318	741	70	14
LOC 044-6-A-D	692	356	99	866	49	G1 1/4	610	584	450	343	779	70	14
LOC 044-4-A-C	692	356	99	866	49	G1 1/4	610	584	450	343	750	70	14
LOC 044-4-A-D	692	356	99	866	49	G1 1/4	610	584	450	343	762	70	14

Key for LOC and LOC2 cooling systems

All positions must be filled in when ordering.

EXAMPLE:

LOC 2 - 011 - 6 - A - C - L - 50 - S20 - D - E0 - 0
1 2 3 4 5 6 7 8 9 10/11 12

1. TYPE OF COOLING SYSTEM = LOC/LOC2

2. COOLER SIZE

004, 007, 011, 016, 023, 033, 044

3. NUMBER OF POLES, MOTOR

4-pole = 4
 6-pole = 6

4. VOLTAGE AND FREQUENCY

Three-phase 220-240/380-420V 50 Hz * = A
 Three-phase 440-480V 60 Hz* = B
 Three-phase 220-240/380-420V 50 Hz 440/480V 60 Hz** = D
 Three-phase 500V 50 Hz = E
 Three-phase 400/690V 50 Hz 440-480 60 Hz = F
 Three-phase 525V 50 Hz = G
 Motor for special voltage (stated in plain language) = X

* for LOC 033 to LOC 044

** for LOC 004 – LOC2 023

5. PUMP SIZE

Displacement 15 cm³/r = A
 Displacement 30 cm³/r = B
 Displacement 45 cm³/r = C
 Displacement 60 cm³/r = D
 Special = X

6. BYPASS VALVE, PUMP

No bypass valve = 0
 Built-in bypass valve, 5 bar internal = L
 Built-in bypass valve, 10 bar internal = H
 Built-in bypass valve, 5 bar external = K
 Built-in bypass valve, 10 bar external = M

7. THERMO CONTACT

For temperature alarm, not for direct control of electric motor.

No thermo contact = 00
 40 °C = 40
 50 °C = 50
 60 °C = 60
 70 °C = 70
 80 °C = 80
 90 °C = 90

8. COOLER MATRIX

Standard = 000
 Two-pass = T00

Built-in, pressure-controlled bypass valve, single-pass

2 bar = S20
 5 bar = S50
 8 bar = S80

*Built-in, pressure-controlled bypass valve, two-pass**

2 bar = T20
 5 bar = T50
 8 bar = T80

Built-in temperature and pressure-controlled bypass valve, single-pass

50 °C, 2.2 bar = S25
 60 °C, 2.2 bar = S26
 70 °C, 2.2 bar = S27
 90 °C, 2.2 bar = S29

*Built-in temperature and pressure-controlled bypass valve, two-pass**

50 °C, 2.2 bar = T25
 60 °C, 2.2 bar = T26
 70 °C, 2.2 bar = T27
 90 °C, 2.2 bar = T29

* = Not valid for LOC 004

9. MATRIX GUARD

No guard = 0
 Stone guard = S
 Dust guard = D
 Dust and stone guard = P

10. FX3 FILTER UNIT (sizing, see page 6)

No filter unit = 0
 Filter unit with 4" element HP = A
 Filter unit with 4" element LP = B
 Filter unit with 8" element HP = E
 Filter unit with 8" element LP = F

11. PRESSURE DROP INDICATOR

No pressure drop indicator = 0
 Visual pressure drop indicator with manual reset. = D
 Visual pressure drop indicator with thermo guard and manual reset. No signal below 0 °C, signal above +29 °C. = P
 Electric pressure drop indicator with automatic reset. Connection in accordance with DIN 43650 ISO 4400 (Hirschmann) IP 65. = M
 Electric pressure drop indicator with 2-pole AMP contact. = U

12. STANDARD/SPECIAL

Standard = 0
 Special = Z

SPARE PARTS

Art. no.	Description
58920102	Filter element 04" HP
58920103	Filter element 04" LP
58920302	Filter element 08" HP
58920303	Filter element 08" LP
589310	O-ring for filter housing cover



With our specialist expertise, industry knowledge and advanced technology, we can offer a range of different solutions for coolers and accessories to meet your requirements.

Take the next step

– choose the right accessories

Supplementing a hydraulic system with a cooler, cooler accessories and an accumulator gives you increased availability and a longer useful life, as well as lower service and repair costs. All applications and operating environments are unique. A well-planned choice of the following accessories can thus further improve your hydraulic system. Please contact us for guidance and information.



Pressure-controlled bypass valve *Integrated*

Guides the oil past the cooler matrix if the pressure drop is too high. Reduces the risk of the cooler bursting, e.g. in connection with cold starts and temporary peaks in pressure or flow. Available for single-pass or two-pass matrix design.



Stone guard/Dust guard

Protects components and systems from tough conditions.



Temperature-controlled bypass valve *Integrated*

Same function as the pressure-controlled bypass valve, but with a temperature-controlled opening pressure – the hotter the oil, the higher the opening pressure. Available for single-pass or two-pass matrix design.



Lifting eyes

For simple installation and relocation.



Thermo contact

Transmitter with fixed temperature indication. For temperature warnings, and for more cost-efficient operation and better environmental consideration through the automatic switching on and off of the fan motor.



Temperature-controlled 3-way valve *External*

Same function as the temperature-controlled bypass valve, but positioned externally.

Note: must be ordered separately.



Production / © Mice Rylander Byra

The Olaer Group develops, manufactures and markets products and systems in six business areas.

Global perspective

and local entrepreneurial flair



The Olaer Group is a global player specialising in innovative, efficient system solutions for temperature optimisation and energy storage.

The Group develops, manufactures and markets products and systems for a number of different sectors, e.g. the aircraft, engineering, steel and mining industries, as well as for sectors such as oil and gas, contracting and transport, farming and forestry, renewable energy, etc. All over the world, our products operate in the most

diverse environments and applications. One constantly repeated demand in the market is for optimal energy storage and temperature optimisation.

We work at a local level with the whole world as our workplace – local entrepreneurial flair and a global perspective go hand in hand.

Our local presence, long experience and a wealth of knowledge combined with our cutting-edge expertise to give you the best possible conditions for making a professional choice.



The Professional Choice – in Fluid Management

Olaer Group Network



THE OLAER GROUP: **AUSTRALIA** Olaer FCH. Tel: +61 2 9981 6888. **AUSTRIA** Olaer Austria GmbH. Tel: +43 7229 80306. **BELGIUM** S.A. Olaer Benelux, Tel: +32 2 466 15 15. **CZECH REPUBLIC** Olaer CZ s.r.o. Tel: +42 5 47125 601-8. **DENMARK** Oiltech DK. Tel: +45 86 69 20 38. **FINLAND** Oiltech Hydraulics OY. Tel: +358 9 413 755 00. **FRANCE** Olaer Industries S.A. Tel: +33 1 41 19 17 00. **GERMANY** Olaer Industries GmbH. Tel: +49 6842 9204-0. **HOLLAND** Olaer Nederland B.V. Tel: +31 76 5412453. **INDIA** FCH India. Tel: +91 802 6533587. **ITALY** Olaer Italiana S.p.A. Tel: +39 011 991 85 11. **KOREA** Hyundai Olaer Hydraulic Co. Tel: +82 31 499 0897. **NORWAY** Oiltech AS. Tel: +47 64 91 11 80. **POLAND** Oiltech Polska. Tel: +48 22 6738162. **SOUTH AFRICA** FCH c/o Rolton Products CC. Tel: +27 11 474 3095. **SPAIN** Olaer-Oiltech Iberica SAU. Tel: +34 933 368 900. **SWEDEN** Oiltech AB. Tel: +46 8 636 07 00. **SWITZERLAND** Olaer (Schweiz) AG. Tel: +41 26 492 70 00. **UK** FCH Ltd. Tel: +44 1244 535515. **USA** Oil Air Hydraulics Inc. Tel: +1 713 937 89 00.

www.oiltech.se